

4MP Mini Fixed Bullet Network Camera

IPC2124SR3-APF40 (60)



Key Features

Optics

- Day/night functionality
- Smart IR , up to 30 m (98 ft) IR distance
- Optical glass window with higher light transmittance
- IR anti-reflection window to increase the infrared transmittance
- 3D DNR (Digital Noise Reduction)

Compression

- H.265, H.264, MJPEG
- Embedded smart algorithm
- Triple streams
- 9:16 corridor format

Network

- ONVIF Conformance

Structure

- Wide temperature range: -35°C to 60°C (-31°F to 140°F)
- Wide voltage range of $\pm 25\%$
- IP67

Specifications

	IPC2124SR3-APF40	IPC2124SR3-APF60
Camera		
Sensor	1/3", 4.0 megapixel, progressive scan, CMOS	
Lens	4.0mm@F2.0	6.0mm@F2.0
Angle of View(H)	80.8°	54.9°
Shutter	Auto/Manual, 1/6~1/100000 s	
Min. Illumination	Colour: 0.02 Lux (F2.0, AGC ON) 0 Lux with IR on	
IR Range	Up to 30m (98 ft) IR range	
Day/Night	IR-cut filter with auto switch (ICR)	
S/N	>52dB	
WDR	Digital	
Noise Reduction	2D/3D	
Video		
Max. Resolution	2592 × 1520	
Video Compression	H.265, H.264, MJPEG	
Frame Rate	4MP (2592 × 1520): Max. 20 fps; 4MP (2560 × 1440): Max. 25 fps 3MP (2048×1520): Max. 30 fps; 1080P (1920×1080): Max. 30 fps	
Video Streaming	Triple	
9:16 Corridor Mode	Supported	
ROI	Supported	
HLC	Supported	
Evaluative Metering	Supported	
OSD	Up to 8 OSDs	
Motion Detection	Up to 4 areas	
Privacy Mask	Up to 8 areas	
Smart		
Behavior Detection	Intrusion, crossing line, motion detection	
Exception Detection	Audio detection	
Intelligent Identification	Face detection, Defocus, Scene Change	
Statistical Analysis	People counting	
Network		
Protocols	L2TP, IPv4, IGMP, ICMP, ARP, TCP, UDP, DHCP, PPPoE, RTP, RTSP, RTCP, DNS, DDNS, NTP, FTP, UPnP, HTTP, HTTPS, SMTP, 802.1x	
Compatible Integration	ONVIF, API	
Interface		
Alarm I/O	1/ 1	
Built-in Mic	Supported	
Network	1 RJ45 10M/100M Base-TX Ethernet	
General		
Power	12 V DC, or PoE (IEEE802.3 af)	
	Power consumption: Max 6.4 W	

Dimensions (L × W × H)	157.3 × 62.4 × 63 mm (6.2" × 2.5" × 2.5")
Weight	0.45 kg (0.99 lb)
Working Environment	-35°C ~ +60°C (-31°F ~ 140°F), Humidity ≤ 95% RH(non-condensing)
Ingress Protection	IP67

Dimensions

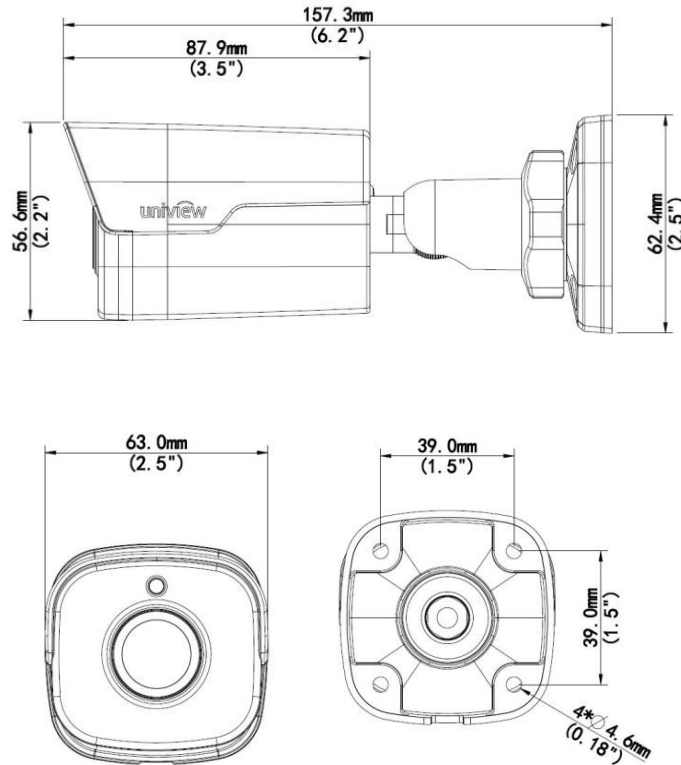

Accessories

Installation mode	Accessories	Description
Wall mount	\	Mounting pedestal is included in the Product package
Ceiling mount	\	Mounting pedestal is included in the Product package

Zhejiang Uniview Technologies Co., Ltd.

Building No.10, Wanlun Science Park, Jiangling Road 88, Binjiang District, Hangzhou, Zhejiang, China (310051)

Email: overseasbusiness@uniview.com; globalsupport@uniview.com

<http://www.uniview.com>

©2017 Zhejiang Uniview Technologies Co., Ltd. All rights reserved.

*Product specifications and availability are subject to change without notice.