

2MP Fixed Dome Network Camera

IPC322LR3-VSPF28(40)-C



Key Features

Optics

- Day/night functionality
- SmartIR, up to 30 m (98 ft) IR distance
- Car-grade LEDs, brighter and uniform light compensation
- 3D DNR (Digital Noise Reduction)

Compression

- H.265, H.264, MJPEG
- Triple streams
- ROI (Region of Interest)

Network

- ONVIF Conformance

Structure

- Wide temperature range: -30°C to 60°C (-22°F to 140°F)
- Wide input voltage range of $\pm 25\%$
- 2-Axis
- IK10 vandal resistant
- IP66

Specifications

	IPC322LR3-VSPF28-C	IPC322LR3-VSPF40-C
Camera		
Sensor	1/2.7", 2 megapixel, progressive scan CMOS	
Lens	2.8 mm@F2.2	4.0 mm@F2.2
Angle of View (H)	105.2°	76.6°
Shutter	Auto/Manual, 1/6~1/100000 s	
Min. Illumination	Colour: 0.2 Lux (F2.2, AGC ON) 0 Lux with IR	
IR Range	Up to 30m (98 ft) IR range	
Day/Night	IR-cut filter with auto switch (ICR)	
S/N	>52dB	
WDR	Digital	
Noise Reduction	2D/3D	
Video		
Max. Resolution	1920 × 1080	
Video Compression	H.265, H.264,MJPEG	
Frame Rate	1080P (1920*1080): Max. 25 fps; 720P (1280*720): Max. 30 fps; D1 (720×576): Max. 8 fps	
Video Streaming	Triple	
Evaluative Metering	Supported	
ROI	Supported	
HLC	Supported	
OSD	Up to 8 OSDs	
Motion Detection	Up to 4 areas	
Privacy Mask	Up to 8 areas	
Network		
Protocols	IPv4, IGMP, ICMP, ARP, TCP, UDP, DHCP, RTP, RTSP, RTCP, DNS, DDNS, NTP, FTP, UPnP, HTTP, HTTPS, SMTP	
Compatible Integration	ONVIF,API	
Interface		
Network	10M/100M Base-TX Ethernet	
General		
Power	12 V DC, or PoE (IEEE802.3 af)	
	Power consumption: Max 5.0W	
Dimensions (Ø x H)	Ø108.5 x 81 mm (Ø4.28" x 3.2")	
Weight	0.3 kg (0.66 lb)	
Working Environment	-30°C ~ +60°C (-22°F ~ 140°F), Humidity ≤ 95% RH(non-condensing)	
Ingress Protection	IP66	

Dimensions

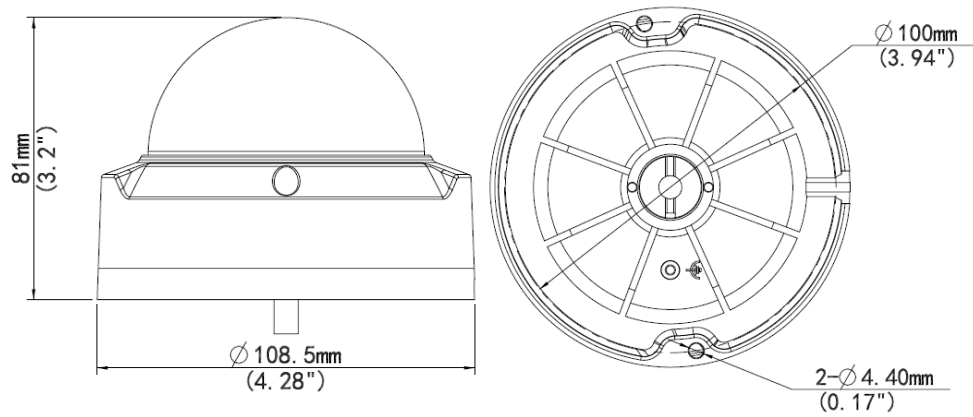

Zhejiang Uniview Technologies Co., Ltd.

South Tower, Building 10, Wanlun Science Park, 88 Jiangling Road, Hangzhou, P.R.China 310051

Email: overseasbusiness@uniview.com; globalsupport@uniview.com

<http://www.uniview.com>

©2017 Zhejiang Uniview Technologies Co., Ltd. All rights reserved.

*Product specifications and availability are subject to change without notice.